

# PHILCO . . . . . Model 38-60—Code 125



## SERVICE BULLETIN No. 279 for members of RADIO MANUFACTURERS SERVICE

### A PHILCO Service Plan

### Electrical Specifications

**TYPE CIRCUIT:** Superheterodyne, with Automatic Volume Control and a pentode audio output circuit.

POWER SUPPLY: Voltage	Frequency	Consumption
115	50 to 60	60 watts
115	25 to 40	60 watts
115/220	50 to 60	60 watts

**INTERMEDIATE FREQUENCY:** 470 K. C.

**TUNING RANGE:** Two—Range one 530 to 1720 K. C.  
Range two 2.3 to 7.4 M. C.

**UNDISTORTED OUTPUT:** 3 watts.

**PHILCO TUBES USED:** One 6A8G, Det. Osc.; one 6K7G, I. F.; one 6Q7G, 2nd Det. audio; one 6F6G, audio output; and one 5Y4G, Rectifier.

**TONE CONTROL:** Two position.

### Alignment of Compensators

**EQUIPMENT REQUIRED:** (1) Signal Generator using a fundamental frequency range covering the intermediate and tuning ranges of the receiver. Philco Model 077 Signal Generator which has a fundamental frequency range from 115 to 36,000 K. C., is the correct instrument for this purpose; (2) output meter, Philco Model 026 circuit tester incorporates a sensitive output meter, and is recommended; (3) Philco Fibre Handle Screw Driver, part No. 27-7059 and Fibre Wrench part No. 3164.

**OUTPUT METER:** The 026 output meter is connected to the plate and cathode terminals of the 6F6G tube. Adjust the meter to use the (0-30) volt scale and advance attenuator control of the generator until a readable indication is noted on the output meter after a signal is applied to the receiver in the following adjustments.

**DIAL CALIBRATION:** In order to adjust this receiver correctly the dial must be aligned to track properly with the tuning condenser. To do this proceed as follows:

- Turn the tuning condenser to the maximum capacity position, then loosen dial hub, set screws and rotate the dial (condenser at maximum capacity) until the glowing beam indicator is centered between the first and second index lines at the low frequency end of the broadcast scale.

- With dial in this position, tighten dial hub set screws.

### INTERMEDIATE FREQUENCY CIRCUIT

Connect the 077 signal generator output lead through a .1 mfd. condenser to the control grid of the 6A8G tube and the ground connection of the output lead to the chassis. Then set the controls of the signal generator and receiver as follows:

- Signal Generator 470 K. C.
- Receiver dial at 580 K. C.
- Range switch of receiver at Range One.
- Volume Control maximum.
- Adjust I. F. Compensator (18B), (18A), (14B), (14A) for maximum output.

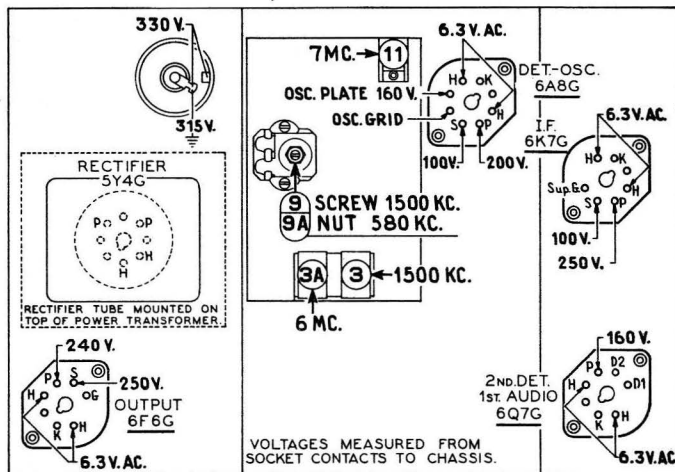

Fig. 1. R. F. Compensators and Voltage Readings, underside of chassis. The voltages indicated by arrows were measured with a Philco 026 Circuit Tester which contains a sensitive voltmeter. Volume control at minimum, range switch in broadcast position, line voltage 115 A. C.

### RADIO FREQUENCY CIRCUIT

#### Tuning Range 530 to 1720 K. C.

1. Connect the signal generator output lead through a 200 mmfd. condenser from the "med" post of the generator to the aerial terminal; and the output lead ground connection to the chassis.

2. The R. F. Compensators are adjusted as follows for maximum output:

Range Switch Position	Signal Generator and Receiver Dial	Compensators In Order
1	1500 K. C.	(9) (3)
1	580 K. C.	(9A) Note A
1	1500 K. C.	(9) (3)

#### Tuning Range 2.3 to 7.4 M. C.

Remove the 200 mmfd. from the output lead and replace with a 400 ohm carbon resistor and reconnect to the antenna terminal.

Range Switch Position	Signal Generator and Receiver Dial	Compensators In Order
2	7.0 M. C.	(11)
2	6.0 M. C.	(3A)

**NOTE A**—First tune compensator (9A) for maximum output, then vary the tuning condenser of the receiver for maximum output about the 580 K. C. dial mark. Now turn compensator (9A) slightly to the right or left and vary the receiver tuning condenser for maximum output. If the output reading increases, turn compensator (9A) in the same direction a trifle more, and again vary the tuning condenser for maximum output. If the output decreases, set the compensator in the opposite direction. This procedure of first setting the compensator and then varying the tuning condenser is continued until there is no further gain in output reading.

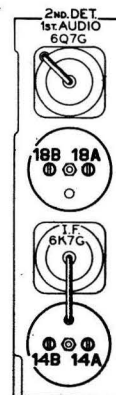

Fig. 2. I. F. Compensators top of chassis

Replacement Parts

Schem. No.	Description	Part No.	List. Price
1	Antenna transformer (range 1)	32-2588	\$1.00
2	Antenna transformer (range 2)	32-2246	.70
3	Compensator (2 section)	31-6093	.40
4	Tuning condenser	31-1826	3.00
5	Condenser (.05 mf. tubular)	30-4444	.20
6	Resistor (10,000 ohms, 1/2 watt)	33-310339	.20
7	Condenser (250 mmf. mica)	30-1032	.25
8	Resistor (120,000 ohms, 1/2 watt)	33-412339	.20
9	Compensator (2 section)	31-6100	.40
10	Oscillator transformer (range 1)	32-2380	.50
11	Compensator	31-6101	.20
12	Condenser (1650 mmf.)	31-6096	.40
13	Oscillator transformer (range 2)	32-2121	.70
14	I. F. Transformer (first)	32-2580	2.20
15	Condenser (.1 mf. tubular)	30-4455	.25
16	Resistor (1 meg., 1/2 watt)	33-510339	.20
17	Resistor (20,000 ohms, 1 watt)	33-320439	.20
18	Second I. F. transformer	32-2582	2.20
19	Condenser (110 mmf.) Part of 18		
20	Resistor (51,000 ohms)	33-351339	.20
21	Condenser (110 mmf.) Part of 18		
22	Volume control	33-5157	1.00
23	Resistor (51,000 ohms, 1 watt)	33-351439	.20
24	Condenser (110 mmf. mica)	30-1031	.20
25	Condenser (.015 mf. tubular)	30-4358	.20
26	Resistor (1 meg., 1/2 watt)	33-510339	.20
27	Condenser (.1 mf. tubular)	30-4122	.20
28	Resistor (1 meg., 1/2 watt)	33-510339	.20
29	Resistor (490,000 ohms, 1/2 watt)	33-449339	.20
30	Resistor (70,000 ohms, 1/2 watt)	33-370339	.20
31	Condenser (.015 mf. tubular)	30-4226	.20
32	Resistor (1 meg., 1/2 watt)	33-510339	.20
33	Output transformer (S7)	32-7019	.85
34	Cone and voice coil assembly	36-3157	1.00
35	Field coil assembly (S7)	36-3039	3.50
36	Condenser (.03 mf. bakelite)	8328-SU	.35
37	Condenser (.008 mf. tubular)	30-4317	.20
38	Condenser (8 mf. electrolytic)	30-2211	
39	Bias resistor (wire wound)	33-3316	
40	Condenser (12 mf. electrolytic)	30-2210	
41	Resistor (9000 ohms, 2 watts)	33-290539	.30
42	Power transformer		
	115 volts, 50-60 cycle	32-7583	4.50
	115 volts, 25-40 cycle	32-7584	6.50
	115/230 volts, 50-60 cycle	32-7585	6.50
43	Condenser (.015 mf.-.015 mf. dual bakelite)	3793-DG	.40
44	Tone control and off-on switch	42-1180	.75
45	Condenser (16 mf. electrolytic)	30-2212	
46	Pilot lamp	34-2039	.07
47	Range switch	42-1333	
	Cable Speaker	L-2181	.25
	Cable A. C.	L-2778	
	Dial	27-5196	.45
	Dial Hub	28-7152	.10
	Dial Clamp	28-2837	.10
	Dial Set Screw	W-1506	2.00
	Knob (Tuning)	27-4321	.10
	Knob (Tone & Volume)	27-4332	.10
	Pilot Lamp Socket Assembly	38-7706	.35
	Screen Bracket Assembly	31-1878	.25
	Speaker S7	36-1009	5.75
	Shaft (Vol. Cont.)	38-8058	.12
	Shaft Spring	28-4117	.40
	Shaft Clip	28-4394	.01
	Socket (6 prong)	27-6086	
	Socket (7 prong)	27-6087	
	Vernier Drive Assembly	31-1863	
<b>F CABINET</b>			
	Baffle & Silk	40-6142	
	Bezel Assembly	40-6130	\$1.00
	Bezel Gasket	27-8312	.01
	Bezel Glass	27-8299	.06
	Bezel Ring	28-5079	.60
<b>B CABINET</b>			
	Baffle & Silk	40-6093	
	Bezel Plate & Frame	40-6117	.90
	Bezel Gasket	27-8311	.01
	Bezel Glass	27-8298	.05
	Bezel Ring	27-5078	.55

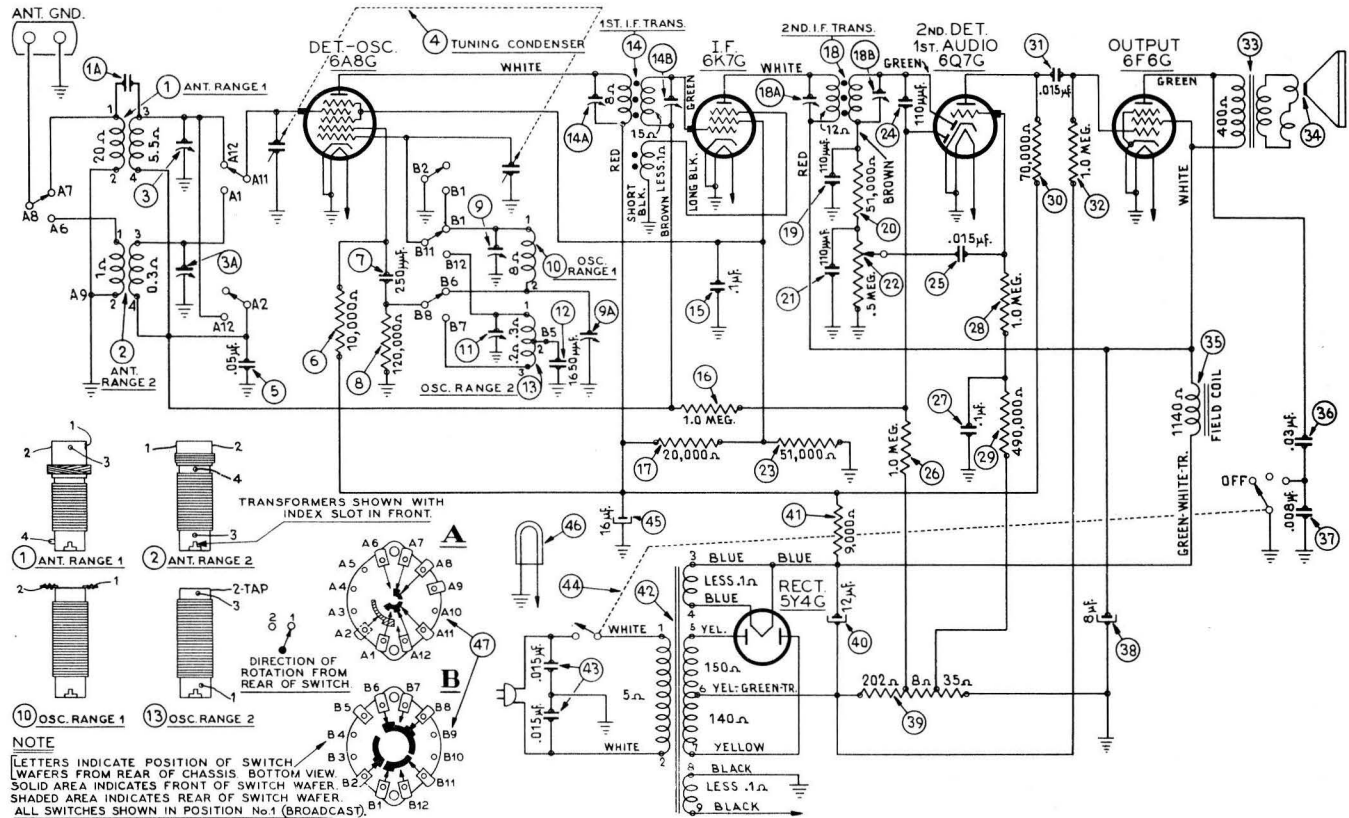

Fig. 3. Schematic Diagram 38-60, Code 125

Schem. No.	Description	Part No.	List Price
	Socket (7 prong)	27-6087	
	Vernier Drive Assembly	31-1863	
<b>F CABINET</b>			
	Baffle & Silk	40-6142	
	Bezel Assembly	40-6130	\$1.00
	Bezel Gasket	27-8312	.01
	Bezel Glass	27-8299	.06
	Bezel Ring	28-5079	.60
<b>B CABINET</b>			
	Baffle & Silk	40-6093	
	Bezel Plate & Frame	40-6117	.90
	Bezel Gasket	27-8311	.01
	Bezel Glass	27-8298	.05
	Bezel Ring	27-5078	.55

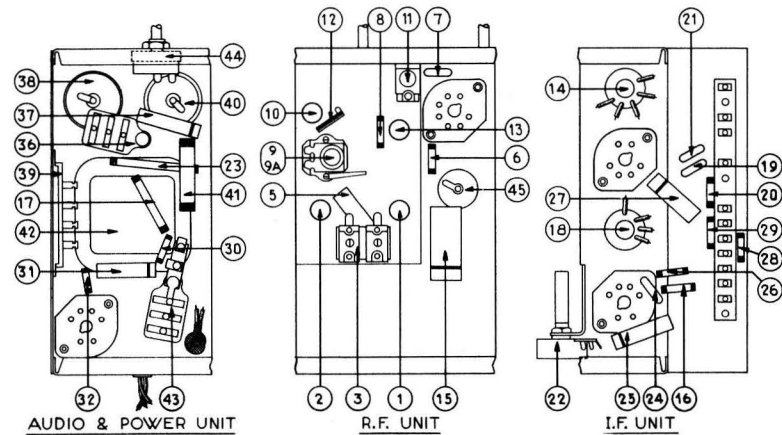

Fig. 4. Part Locations, underside of chassis

PHILCO RADIO AND TELEVISION CORPORATION

Parts and Service Division

Philadelphia, Pa.